

CAPACITY	SYMBOL/ SERIAL NO.	CIRCUIT DIAGRAM
DC 24V		
40W x 1		

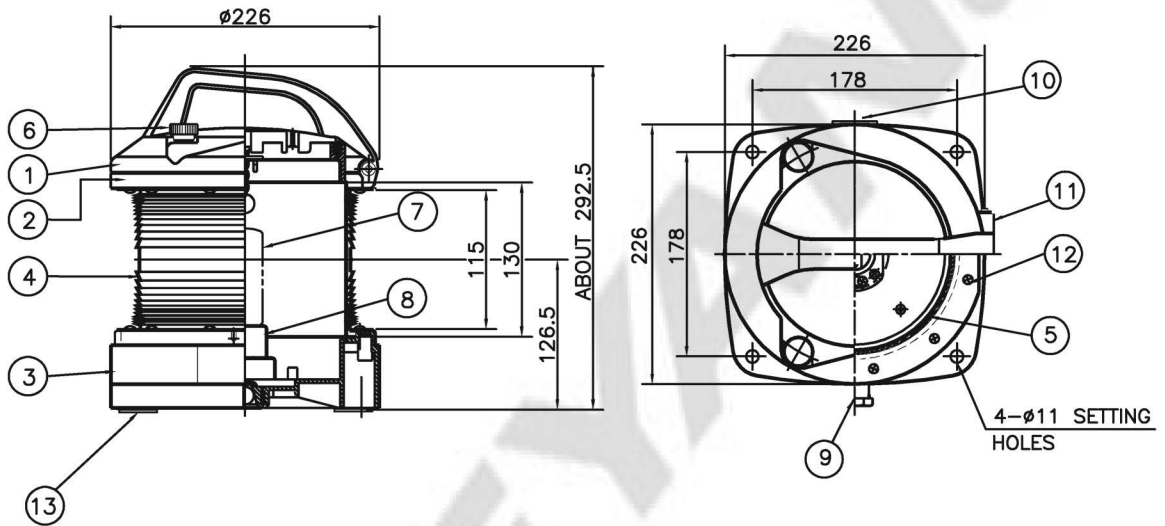

**NOTE**

1. APPLICATION RANGE : VESSEL OF 50M IN LENGTH AND ABOVE
2. MINIMUM VISIBILITY : 3 N.M
3. W/1.5M CABLE (TPNP 1.5SQ)

**\* CAUTION!!**

Do not install the navigation light upside down.  
 Since breathing device is installed on the bottom of fixture.  
 (설치 시 주의하십시오. 항해등의 바닥에는 호흡기가 설치되어 있으므로 거꾸로 설치하지 마십시오.)

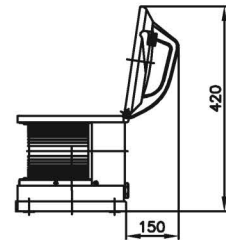

MAINTENANCE SPACE

13	ANTI-VIBRATION PACKING	C.R.	4	5mm					
12	T/H TAPPING SCREW	STAINLESS STEEL 304	24	M4	6	CLAMP BOLT	BRASS	2	
11	HINGE	POLYCAR-BONATE	1		5	GASKET	SILICONE RUBBER	1	
10	NAME PLATE	STAINLESS STEEL 316L	1		4	LENS	POLYCAR-BONATE	1	DARK WHITE
9	CABLE GLAND	NYLON	1	#20a~c (φ12~15)	3	BODY	POLYCAR-BONATE	1	
8	LAMP HOLDER	PPS	1	P28s	2	TOPPER	POLYCAR-BONATE	1	
7	NAVIGATION LIGHT LAMP	-	1	P28s	1	COVER	POLYCAR-BONATE	1	
NO	NAME OF PARTS	MATERIAL	Q'TY	REMARKS	NO	NAME OF PARTS	MATERIAL	Q'TY	REMARKS

APPROVED	B. K. KIM	UNIT	MM	TITLE; <b>WHITE LIGHT (ANCHOR) FOR MARINE USE</b>			
CHECKED		SCALE	N/S				
DRAWING	B. I. KIM	COLOR	MAT BLACK				
DATE	2015.12.04	IP	56				
				MODEL NO.	A2P-SW4024Hh-1.5M-MED	WEIGHT	2.9 kg
				DWG NO.	L31150110	SHEET NO.	26